

Service Manual

Cordless Rotary Hammer

EY6812

CONTENTS

	Page
• Specifications	1
• Disassembly & Assembly Instructions	2 - 5
• Wiring Connection Diagram	6
• Schematic Diagram	6
• Troubleshooting	7 - 8
• Trial operation	9
• Exploded View	10
• Replacement Parts List	11

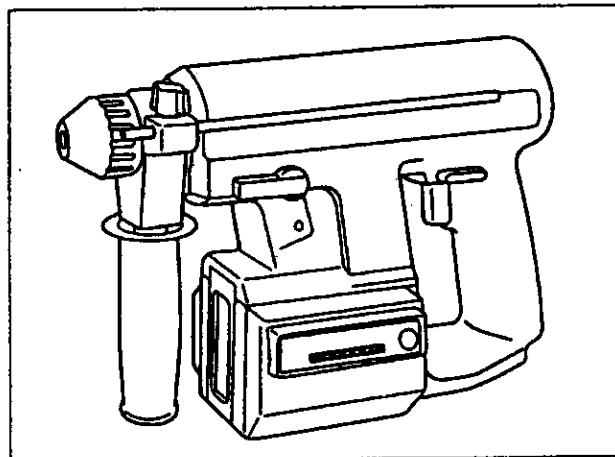

SPECIFICATIONS

MAIN UNIT

Maximum drilling diameter	: <concrete>	20mm (25/32")
Motor voltage	: 24V DC	
Revolutions	: 0 ~ 950 min ⁻¹ (r.p.m.)	
Blows	: 0 ~ 4600 min ⁻¹ (r.p.m.)	
Weight (with battery pack)	: 3.6kg (8.0lbs.)	
Dimensions (L × W × H)	: 291 × 199 × 68mm	(11-29/64" × 7-53/64" × 2-43/64")

BATTERY PACK

Storage battery	: Ni-Cd battery
Battery voltage	: 24V DC (1.2V × 20 cells)

BATTERY CHARGER

Input	: 120V AC
Weight	: 1.30kg (2.90lbs.)
Charging time	: Approx. 30 min. for EY9117

STANDARD EQUIPMENT

Battery charger , Battery pack , Tool case

⚠ WARNING

This service literature is designed for experienced repair technicians only and is not designed for use by the general public. It does not contain warnings or cautions to advise non-technical individuals of potential dangers in attempting to service a product. Products powered by electricity should be serviced or repaired only by experienced professional technicians. Any attempt to service or repair the product or products dealt with in this service information by anyone else could result in serious injury or death.

Panasonic

© 1998 Matsushita Electric Works, Ltd.
All rights reserved. Unauthorized copying and distribution is a violation of law.

DISASSEMBLY INSTRUCTIONS

■ HOW TO DISASSEMBLE THE MAIN UNIT. (Internal mechanism block can be disassembled into several blocks after housing A and B are removed.)

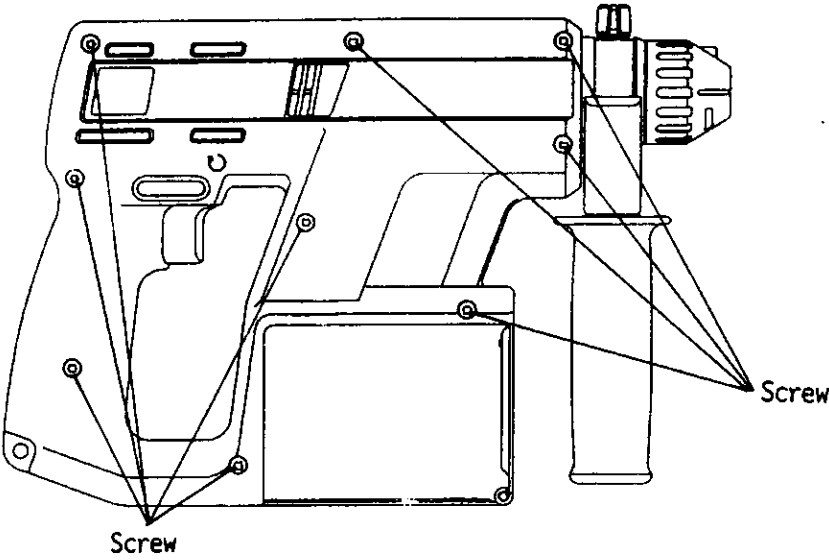
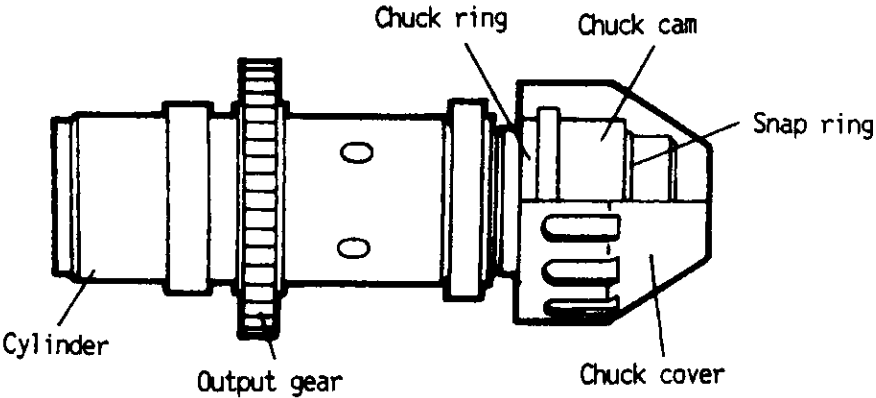
Ref. No. 1A	Procedure 1A	Removal of the housings.
		<p>1. Remove 9 screws of the housing.</p> 
		<p>1. To remove the chuck cover, insert a flat screw driver into the clearance between the the cover and chuck ring. Pry the cover off.</p> <p>2. The chuck cam can be pulled out by removing the snap ring.</p> 

Ref. No. 3A	Procedure 1A → 2A → 3A	Removal of the intermediate shaft block.
-------------	------------------------	--

1. Remove the piston and hammer block from the intermediate shaft block.

NOTE: This block serves in switching the tool from hammer to drill mode.

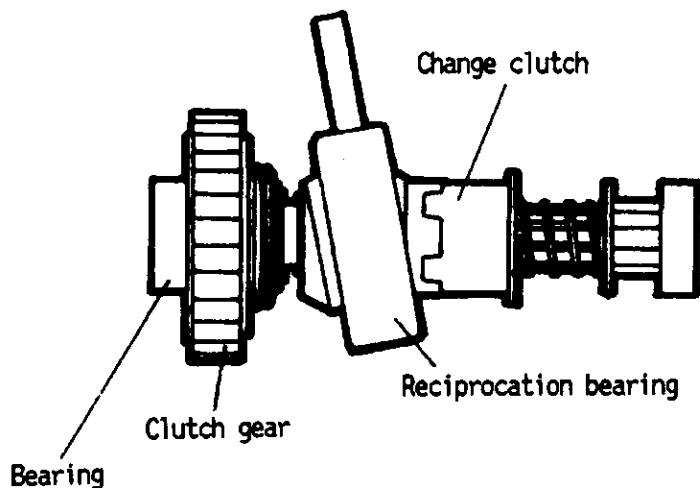

Ref. No. 4A	Procedure 1A → 2A → 3A → 4A	Removal of the piston and hammer block.
-------------	-----------------------------	---

1. Remove the piston from hammer.

NOTE : Air compressed by the piston drives hammer. Take care to protect the piston and hammer from contamination by dust.

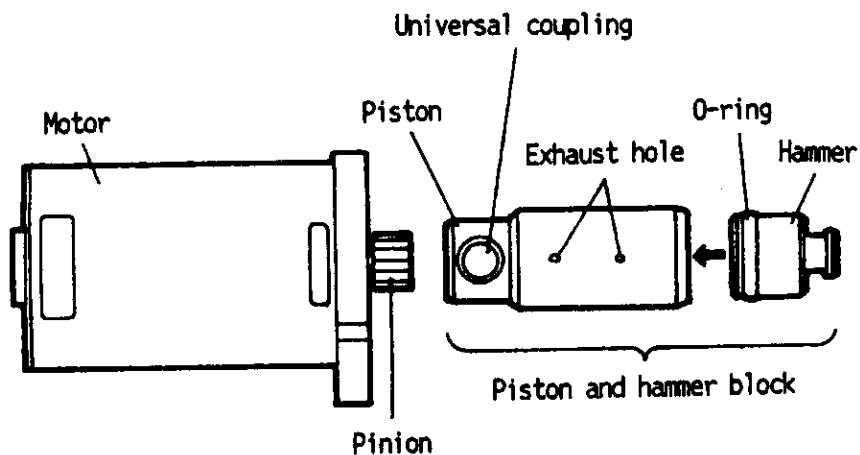

ASSEMBLY INSTRUCTIONS

■ HOW TO ASSEMBLE THE INTERNAL MECHANISM BLOCK.

(Assembly should be done block by block, in order of intermediate shaft block, output shaft block and hammer w/piston block.

◎ Use specific grease (SHELL ASG-7) supplied by the part number (EY6811X5517) for mechanism part.

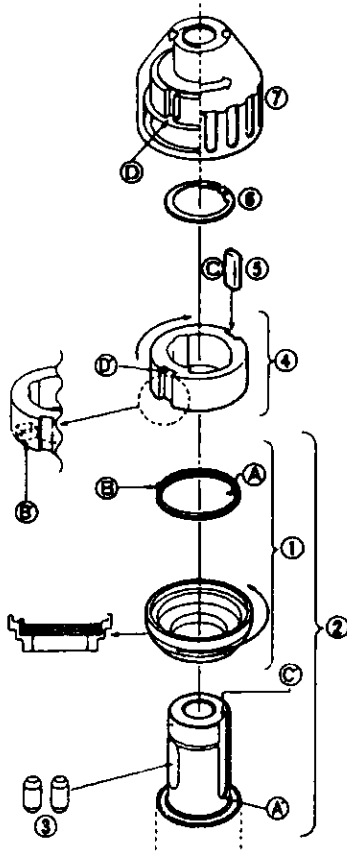
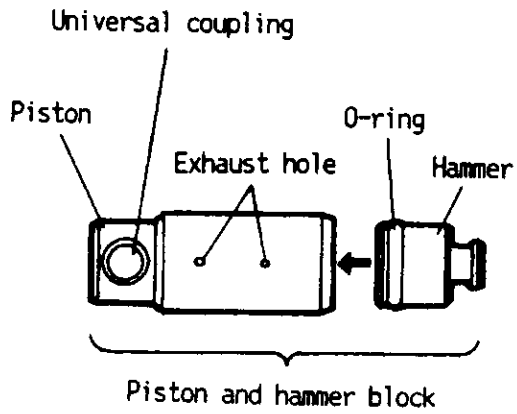
Ref. No. 1A	Procedure 1A	Assembly of the output shaft block.
		<ol style="list-style-type: none"> 1. Check the direction of the chuck spring with setting (B) part upward. Press and screw the spring into the chuck ring. 2. Insert the chuck ring block into the output shaft block with adjusting (A) part of spring to (A') part of the output shaft block. 3. Put the transmission keys into the right and left side of the output shaft block. 4. Assemble the chuck cam with setting (B') part downward to the output shaft block. <p>NOTE: After inserting the chuck cam into the output shaft block, slightly turn the chuck cam clockwise direction; and turn the chuck ring counterclockwise direction to adjust the (B) part of spring to (B') part of chuck cam.</p> <ol style="list-style-type: none"> 5. Insert the chuck key (C) into the output shaft block (C') part. 6. Set the snap ring. 7. Assemble the chuck cover with fitting the (D) part of chuck cover and (D') part of chuck cam.
Ref. No. 2A	Procedure 1A → 2A	Assembly of the piston and hammer block.
		<ol style="list-style-type: none"> 1. When inserting the hammer into piston, clean around the exhaust holes. 2. When inserting the hammer into the piston, make sure that its orientation is correct. <p>NOTE : In particular, hammer O-ring, inside of the piston and cylinder of output shaft block require adequate greasing as they are subject to heating from compressed air.</p>

Ref. No. 3A

Procedure 1A → 2A → 3A

Assembly of the mechanism block.

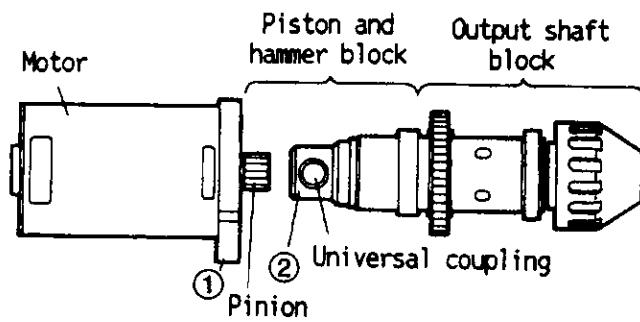

1. Set the bearing of intermediate shaft block in the hole of motor block with adjusting the cogs between motor pinion and bearing.
2. Insert the reciprocation bearing shaft into the hole of universal coupling. Make sure two thrust plates should be set both side of reciprocation bearing shaft one of each.
3. Assemble intermediate shaft block, piston with hammer block and output shaft block on the housing.

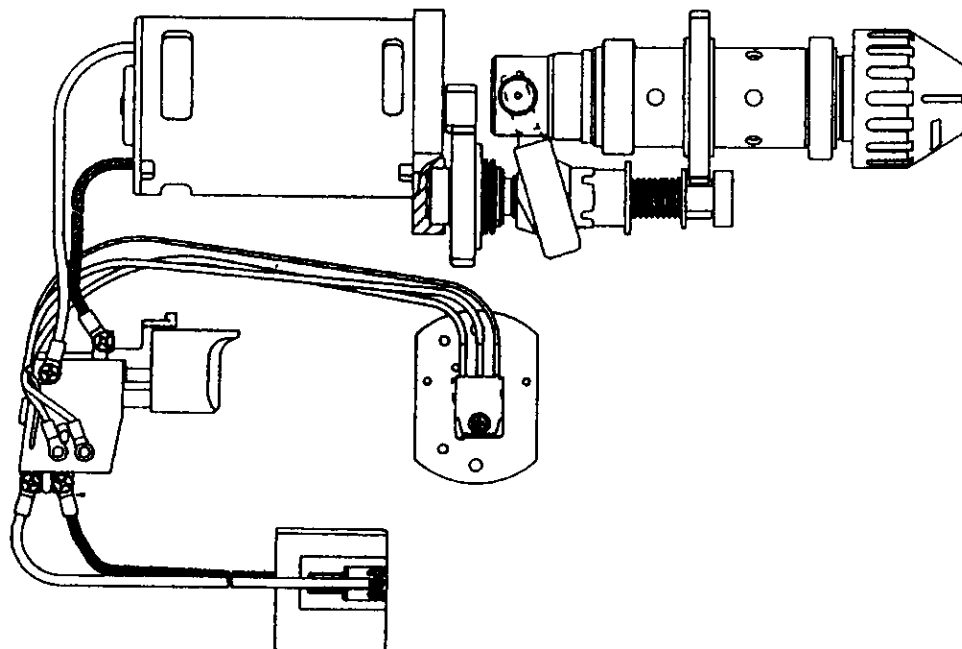
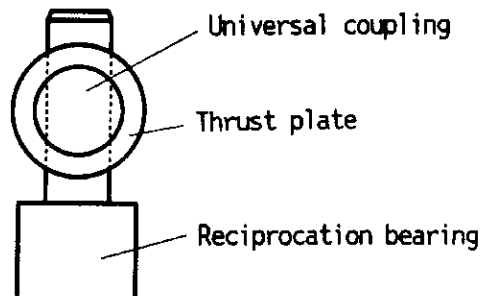
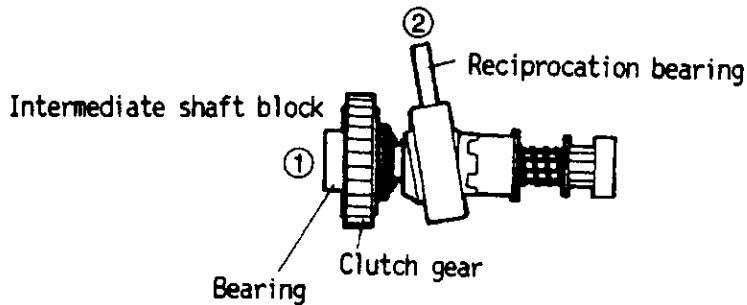

SCHEMATIC DIAGRAM

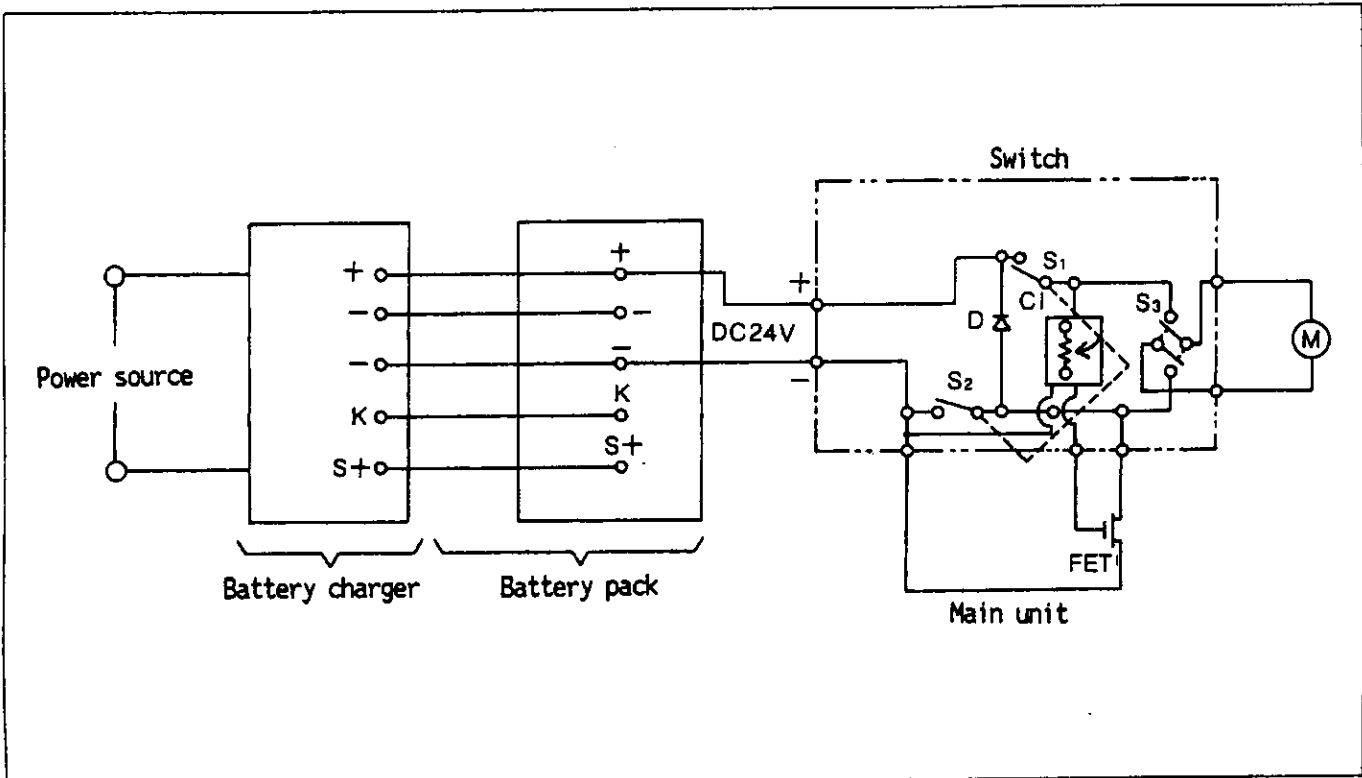

WIRING CONNECTION DIAGRAM

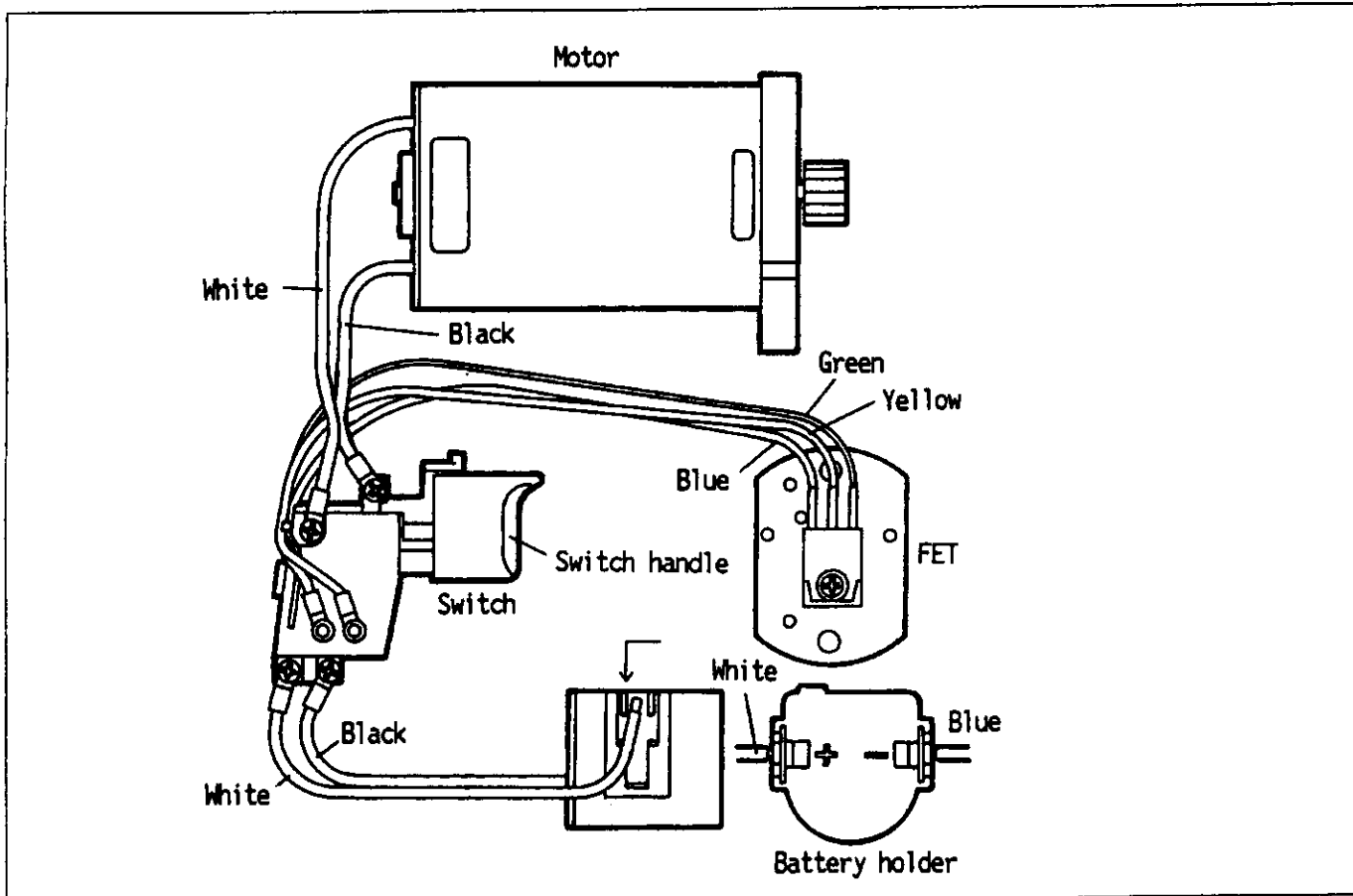

TROUBLESHOOTING GUIDE (Refer to WIRING CONNECTION DIAGRAM)

■ CHECK POINTS FOR ELECTRICAL PARTS
 < TROUBLE >

< CHECK >

< REMEDY >

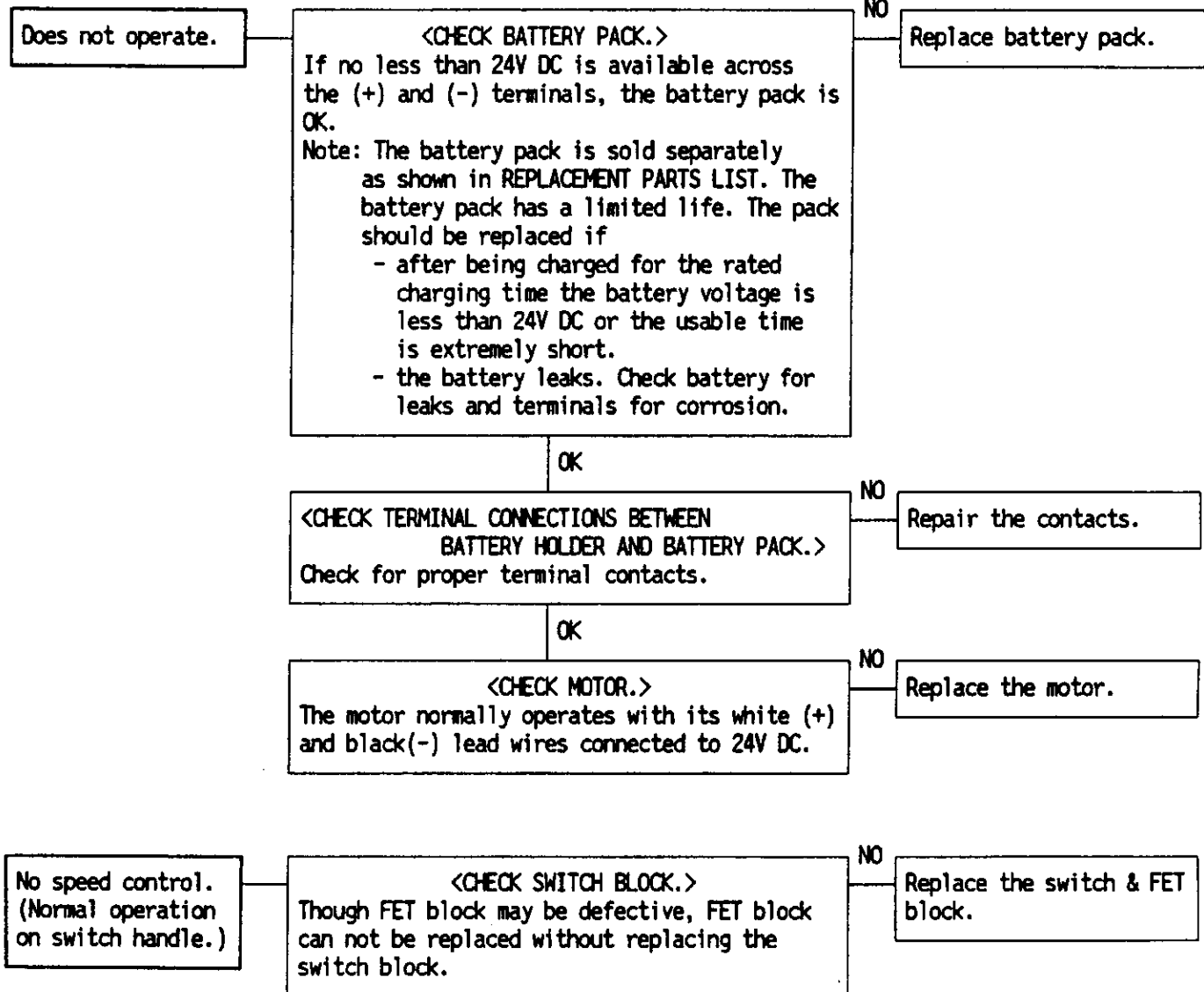

■ CHECK POINTS FOR MECHANISM BLOCK
 < TROUBLE >

< CHECK >

< REMEDY >

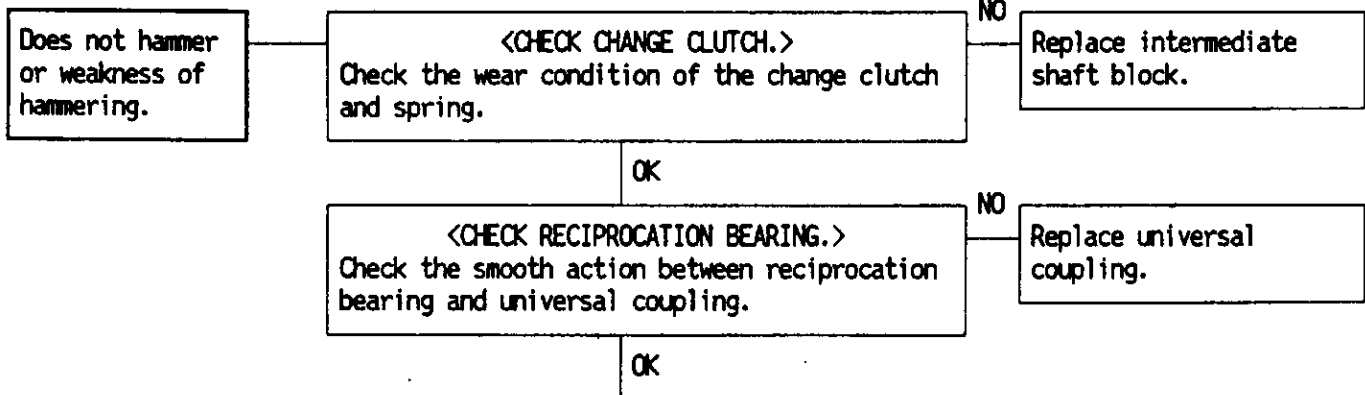

(to be continued)

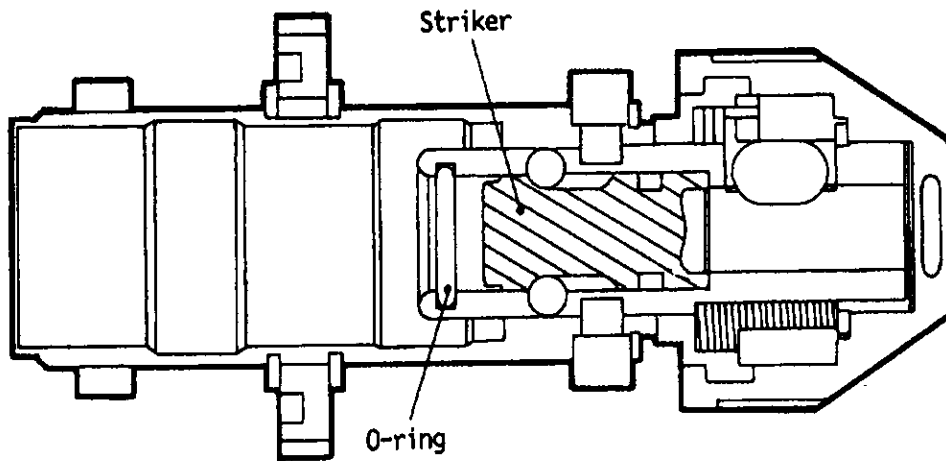
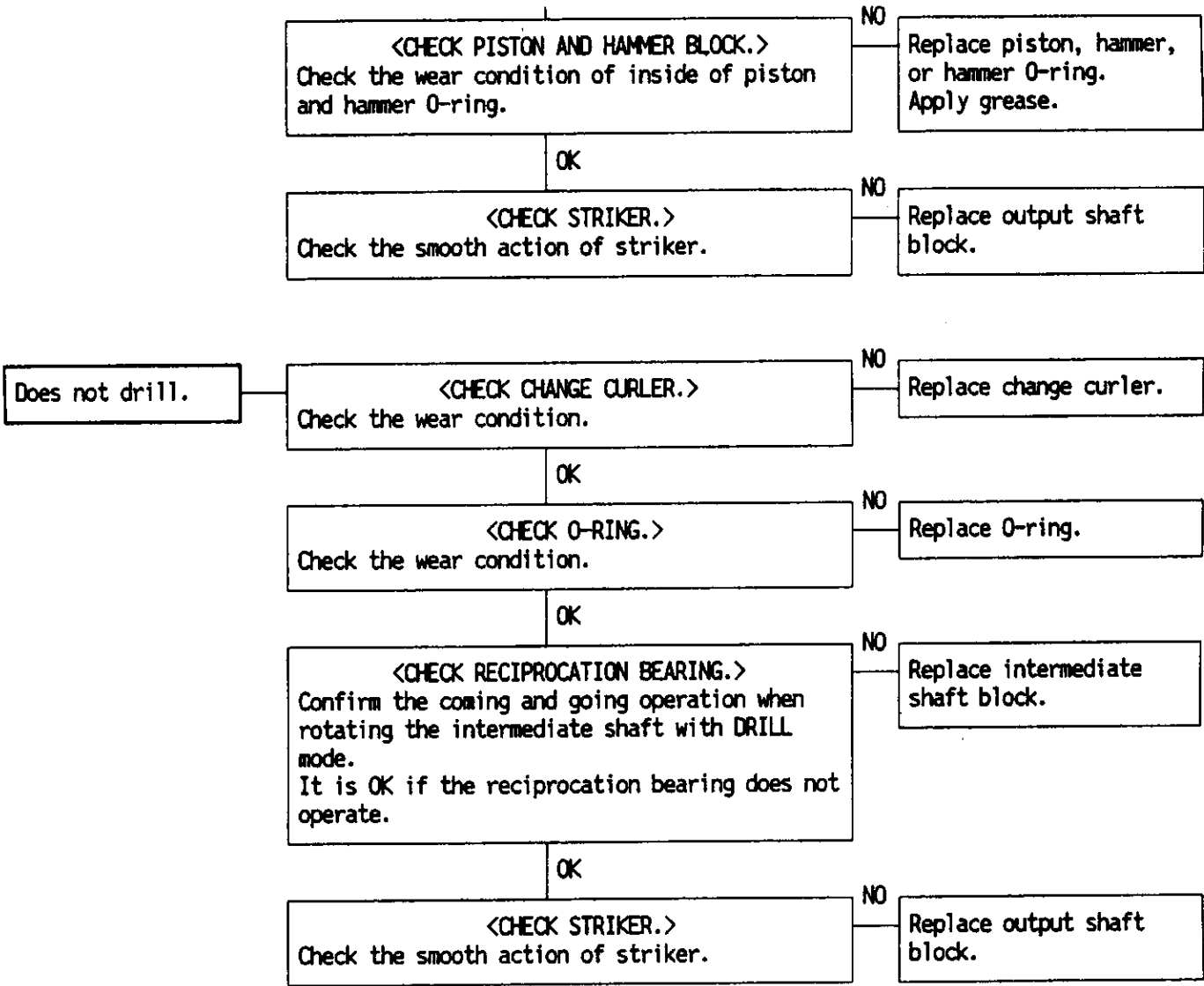

TRIAL OPERATION (After checking TROUBLESHOOTING GUIDE.)

■ **HAMMER/DRILL**

Confirm the action when setting the H/D handle to HAMMER mode.

Rotation with hammering when the drill bit touches something like stone, and power.

It is OK if it takes about 7~10 seconds by 20kgf to hole ($\phi 12.5 \times 40$) on the concrete (pressure strength 240kgf/cm²).

Confirm the action when setting the H/D handle to DRILL mode.

No hammering when the drill bit touches iron plate.

■ **SPEED CONTROL**

Change the rotation speed in proportion to the amount of pushing level on switch lever.

0 ~900 rpm

■ **REVERSING LEVER**

Confirm the action with setting the reversing lever to FORWARD or REVERSE.

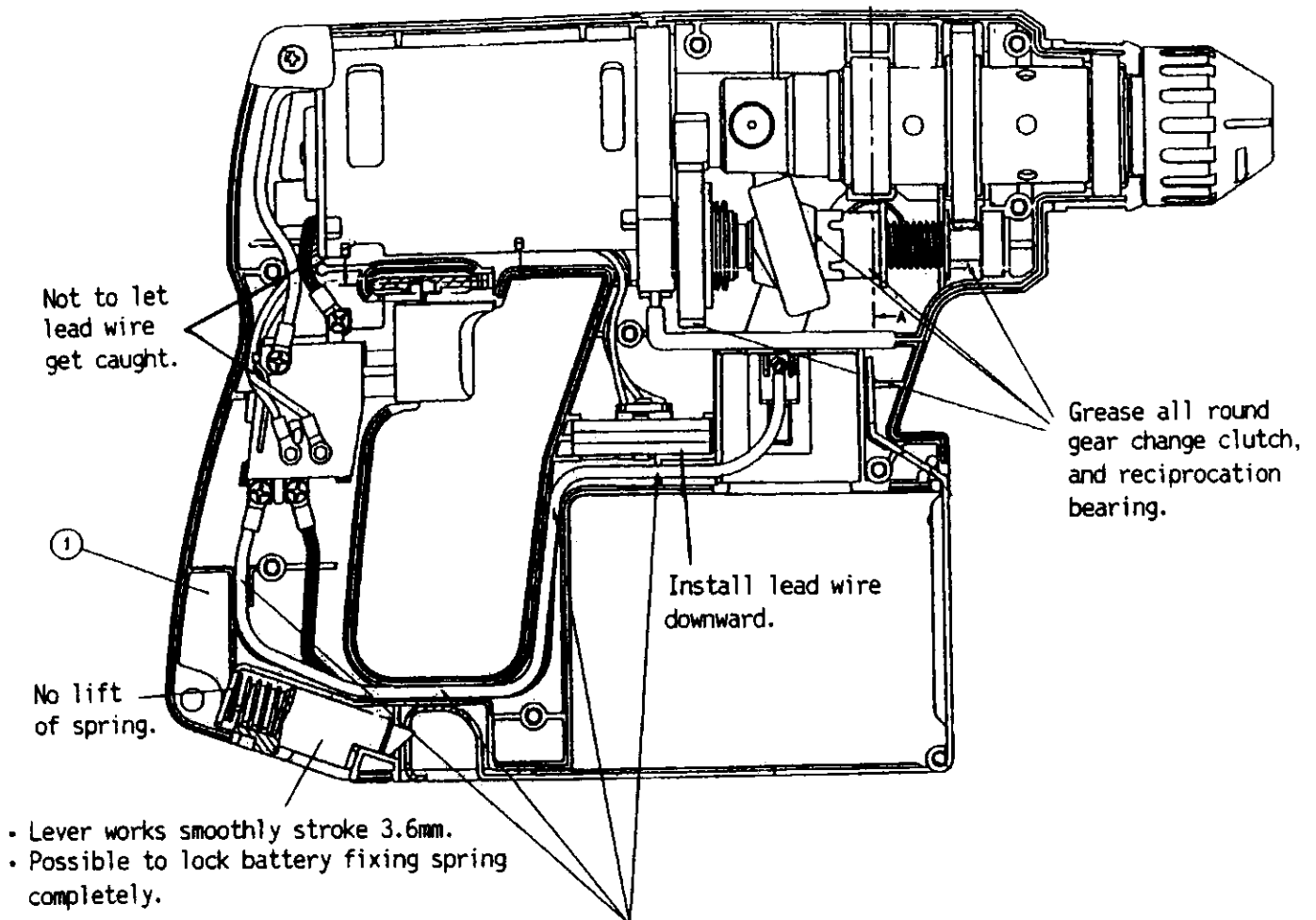

Press lead wire between ribs in housing completely.

EXPLODED VIEW

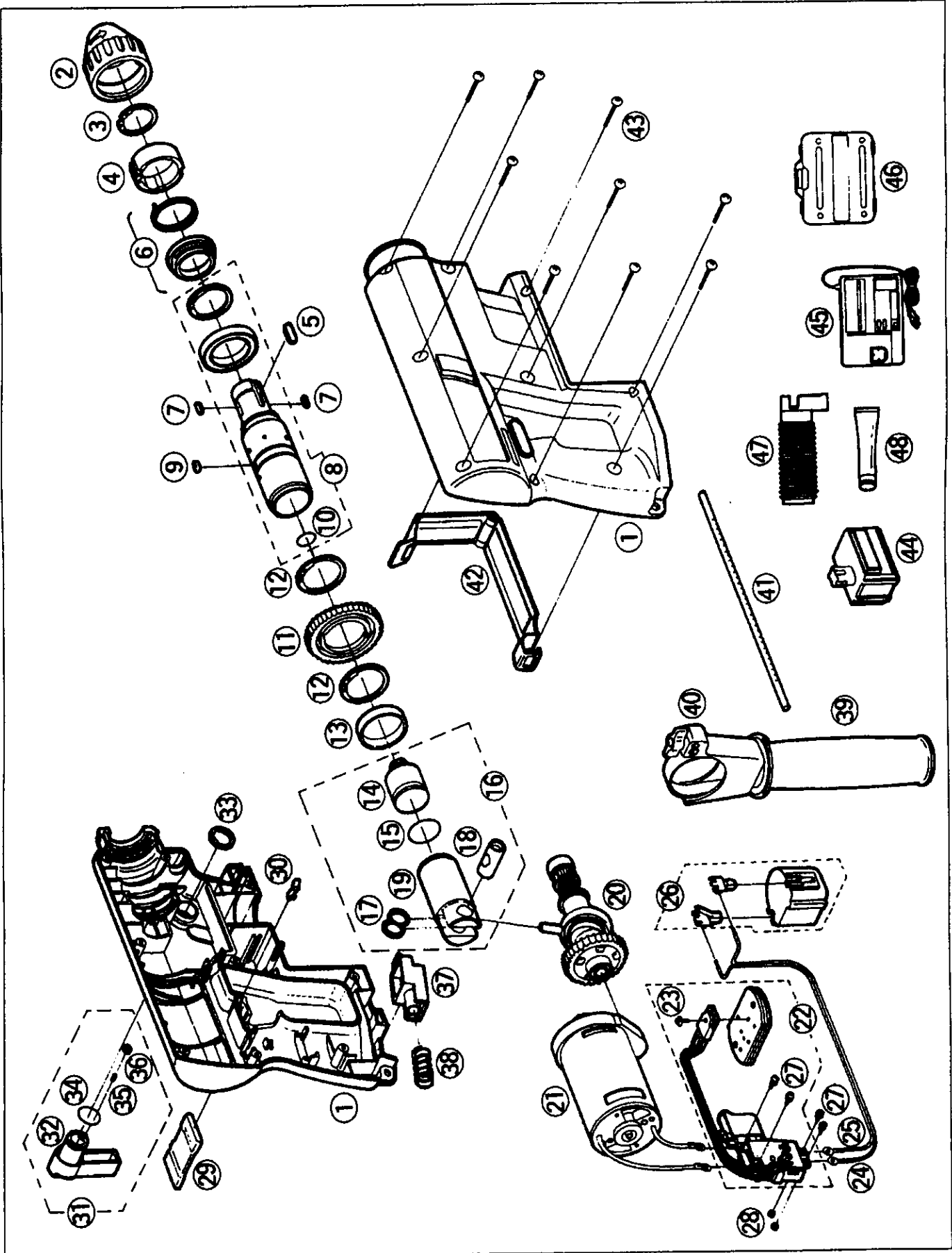

REPLACEMENT PARTS LIST

NOTE : *A . . . available as an optional accessory
 *B . . . only available as set
 *C . . . available individually

Ref. No.	Part No.	Part Name & Descriptions	Per unit	Remarks
▲ 1	EY6812K3078	HOUSING AB SET	1	
2	EY6802H3117	CHUCK COVER	1	
▲ 3	EY6812L0417	SNAP RING	1	φ 20
4	EY6802K1377	CHUCK CAM	1	
5	EY6802K1387	CHUCK KEY	1	
6	EY6802K0687	CHUCK RING	1	
7	EY531B0477	TRANSMISSION KEY	2	*C
▲ 8	EY6812L1128	OUTPUT SHAFT	1	
▲ 9	EY6812L1387	SPINDLE GEAR KEY	1	
▲ 10	EY6812L0987	O-RING	1	P12.5
▲ 11	EY6812L1417	POWER GEAR	1	
▲ 12	EY6812X0417	SNAP RING	2	*B φ 30
▲ 13	EY6812L0387	BEARING	1	
▲ 14	EY6812L4627	HAMMER	1	
▲ 15	EY6812L0977	O-RING	1	
▲ 16	EY6812L1247	PISTON HAMMER BLOCK	1	
▲ 17	EY6812L0847	THRUST PLATE	2	*B
▲ 18	EY6812L1447	UNIVERSAL COUPLING	1	
▲ 19	EY6812L1987	PISTON	1	
▲ 20	EY6812L1137	INTERMEDIATE SHAFT	1	
▲ 21	EY6812L1007	MOTOR	1	
▲ 22	EY6812Y2008	SWITCH	1	
▲ 23	EY6812L6017	TAPPING SCREW	1	2.6*8
▲ 24	EY6812L2967	LEAD WIRE (WHITE)	1	
▲ 25	EY6812L2977	LEAD WIRE (BLACK)	1	
▲ 26	EY6811L3737	BATTERY HOLDER	1	
27	EY6230L6037	SEMS SCREW	4	*C M3*5
▲ 28	EY6812L6417	HEX NUT	2	*C M3
▲ 29	EY6812H3247	F/R SELECTOR HANDLE	1	
30	EY6481L0177	CLICK SPRING	1	
▲ 31	EY6812H3217	H/D SWITCHING LEVER	1	
▲ 32	EY6812H3227	H/D HANDLE	1	
▲ 33	EY6812X0427	SNAP RING	1	φ 13
▲ 34	EY6812L0968	O-RING	1	M13.6
▲ 35	EY6812L1347	CHANGE SHAFT	1	
▲ 36	EY6812L0837	CHANGE CURLER	1	
▲ 37	EY6812H3827	RELEASE LEVER	1	
▲ 38	EY6812L0177	SPRING A	1	
▲ 39	EY6811H3237	AUXILIARY HANDLE	1	
▲ 40	EY6811H6507	WING NUT	1	
▲ 41	EY531B7727	DEPTH GAUGE	1	
▲ 42	EY6811K3817	BATTERY FIXING SPRING	1	
43	EY3503K6208	TAPPING SCREW	9	*C K4-20
▲ 44	EY9117	BATTERY PACK	2	*A
▲ 45	EY0212	BATTERY CHARGER	1	*A
▲ 46	EY9513	TOOL CASE	1	*A
▲ 47	EY9730	DUST COLLECTING CUP	1	*A
▲ 48	EY6812T7918	GREASE	1	
▲ -	EY6812K8008	INDIVIDUAL BOX	1	
▲ -	EY6812K8108	OPERATING INSTRUCTIONS	1	